

エバラSRM4型片吸込マルチエースファン
EBARA SINGLE SUCTION MULTIACE FAN

極数 4P
POLE 4P

トップランナーモータ搭載
with top runner motor

外形寸法図
DIMENSIONS

機名 MODEL 4SRM4

周波数 FREQUENCY 60 Hz

床置形
FLOOR TYPE

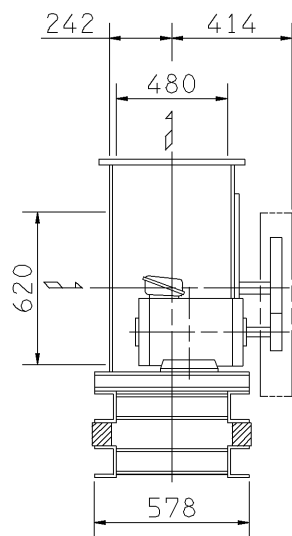

f-A型

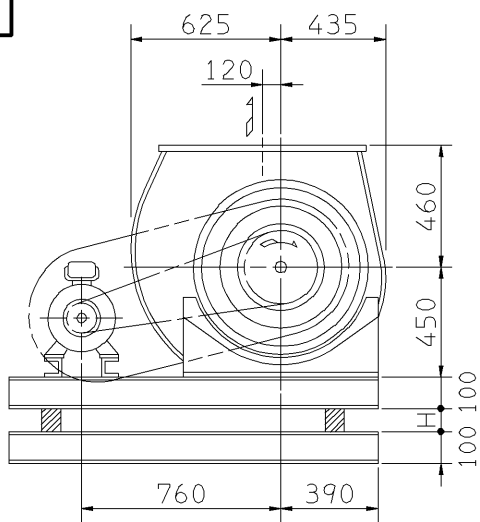

f-B型

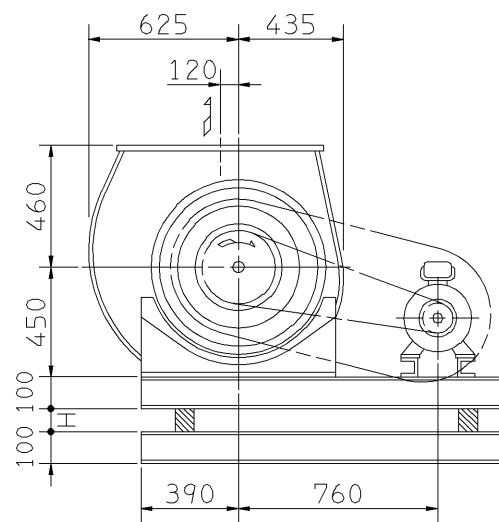

f-C型

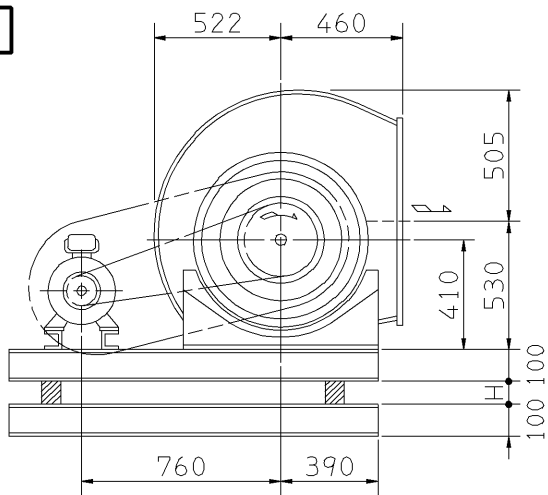

f-D型

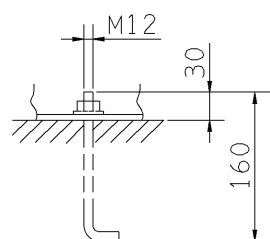
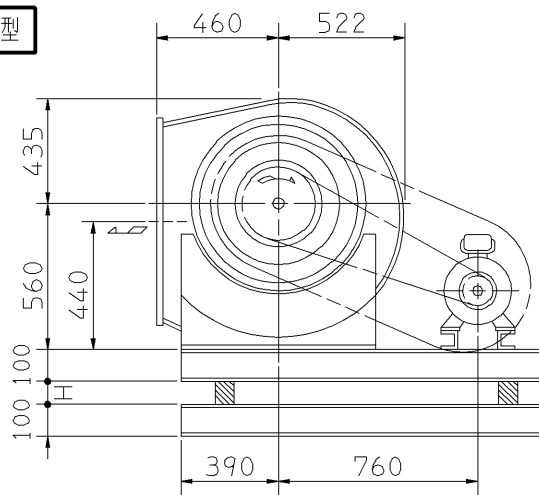

推奨基礎ボルト
RECOMMENDABLE
ANCHOR BOLT

基礎ボルトは付属いたしません。
ANCHOR BOLTS ARE OUT OF SUPPLY.

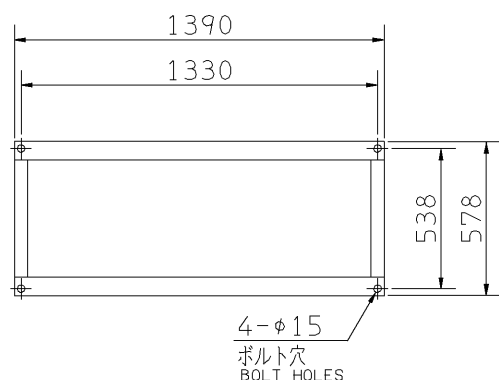

基礎図
FOUNDATION PLAN

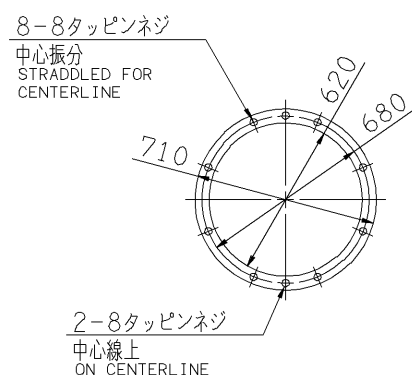

吸込フランジ
SUCTION FLANGE

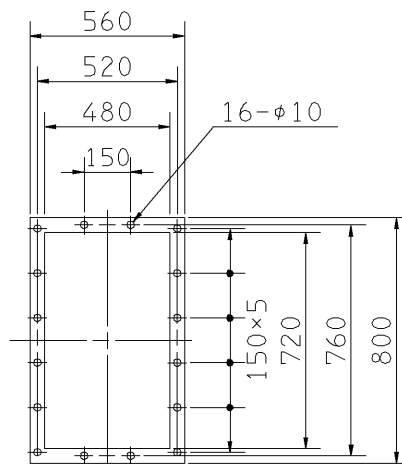

吐出しフランジ
DISCHARGE FLANGE

- 注) 1. 本図は、駆動側(プーリ側)より見た図です。
NOTE DRAWING SHOWS THE DIMENSIONS VIEWED FROM PULLEY SIDE.
2. 機器の取付け、配管等は取扱説明書を参照してください。
FOR INSTALLATION PLEASE REFER INSTRUCTION MANUAL.
3. 本図は、エバラ標準電動機を使用した場合の図です。
MOTORS ARE IN ACCORDANCE WITH EBARA STANDARDS.

出力 OUTPUT kW	回転速度 SPEED min ⁻¹	Vプーリ組合せ V PULLEY		Vベルト V BELT			概略寸法 HEIGHT H	概略質量 MASS kg			
		電動機側 MOTOR SIDE	ファン側 FAN SIDE	型 TYPE	数 Q'TY	呼称(号) SIZE f-A f-B f-C f-D					
1.5	380	67	315	3V	2	900	900	900	20	194	
		425	75	315	3V	1	900	900			950
2.2	480	75	315	3V	2	900	900	900	20	204	
		85	315	3V	1	900	900	950			
		530	75	250	3V	2	850	850			900
3.7	570	85	315	3V	2	900	900	900	20	214	
		85	280	3V	2	850	850	900			
		95	300	3V	2	900	850	900			
		600	85	250	3V	2	850	850			900
5.5	650	90	280	3V	3	850	850	900	20	234	
		85	250	3V	3	850	850	850			
		90	250	3V	3	850	850	900			
		705	125	315	3V	2	900	900			950
7.5	750	110	300	3V	3	900	900	900	20	251	
		100	250	3V	3	850	850	900			
		95	224	3V	3	850	800	850			
		785	112	250	3V	3	850	850			900
11	820	110	236	3V	3	850	850	900	20	281	
		705	125	315	3V	3	900	900			950
		750	120	280	3V	3	900	850			900
		785	125	280	3V	3	900	850			900

付属品 ACCESSORIES		特別付属品 SPECIAL ACCESSORIES		電動機 MOTOR		特殊仕様 SPECIAL SPEC.	
1	軸受(駆動側) UCF209 BG (PULLEY SIDE)	8	防振材(ゴム) ISOLATORS (RUBBER)	1	周波数 Hz	Hz	
2	軸受(反駆動側) UCP206 BG (OPPOSITE SIDE)	9	防振ベース VIBRO ISOLATING BASE	2	電圧 V	V	
3	Vプーリ V PULLEY	10		3	出力 kW	kW	
4	Vベルト V BELT	11		4	形式 TYPE		
5	Vベルトガード V BELT GUARD	12		5	メーカー MAKER		
6	共通ベース COMMON BASE	13		6			
7	相フランジ COMPANION FLANGE	14		7			

御注文主 CUSTOMER				機器番号 ITEM NO.			
御使用先 FINAL USER				機器名称 ITEM NAME			
原製番 SER.NO.	機名 MODEL	風量 CAPACITY	静圧 STATIC PRESS.	回転速度 SPEED	出力 OUTPUT	数量 Q'TY	
				min ⁻¹			

図番 DWG.NO. Z4SRM46AF 000



Z4SRM46AF