

エバラSRM4型片吸込マルチエースファン
EBARA SINGLE SUCTION MULTIACE FAN

極数 4P
POLE 4P

トップランナーモータ搭載
with top runner motor

外形寸法図
DIMENSIONS

機名 MODEL 4SRM4

周波数 FREQUENCY 50 Hz

二重天井吊り
HANGER TYPE

天井吊り形
HANGER TYPE

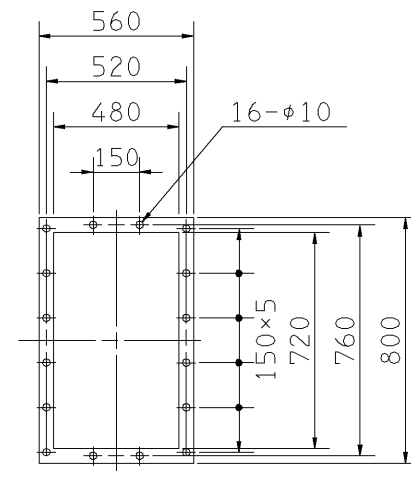
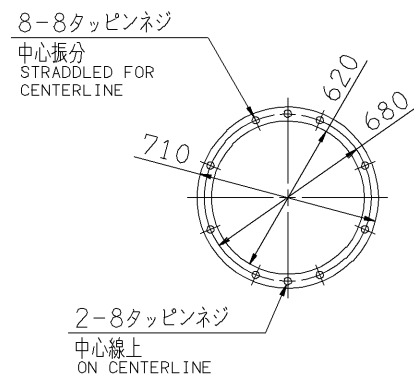
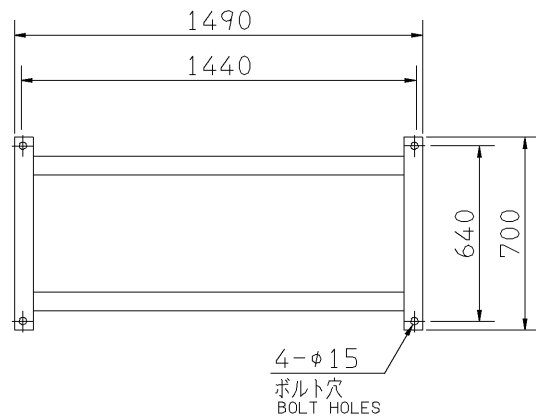
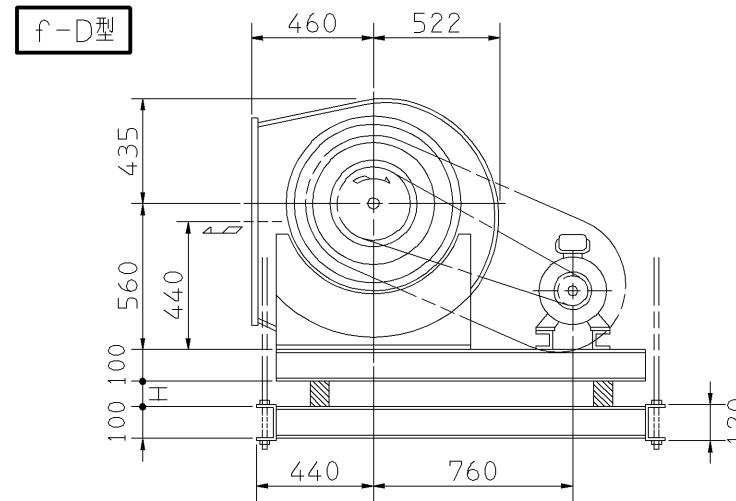
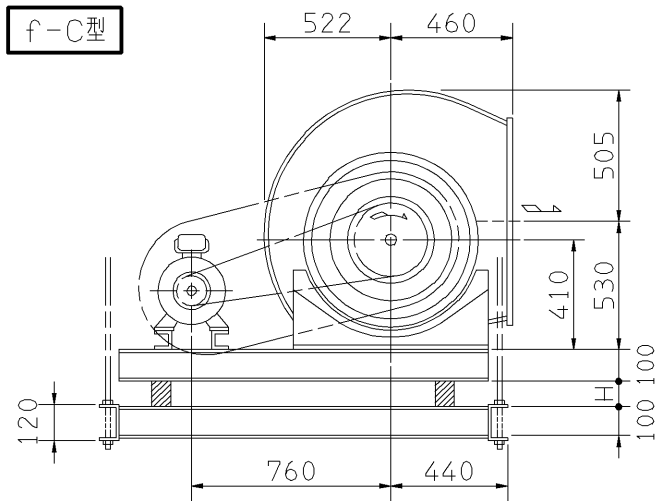
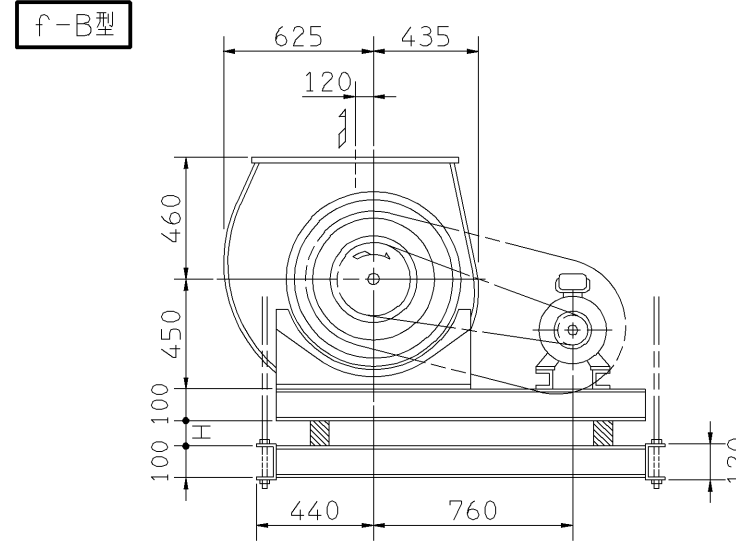
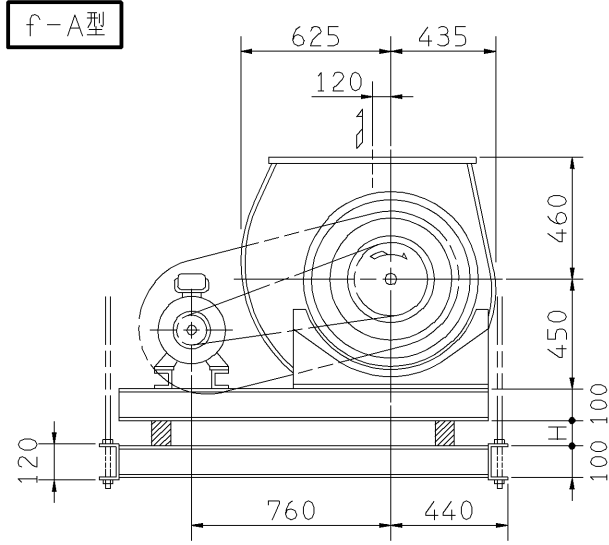
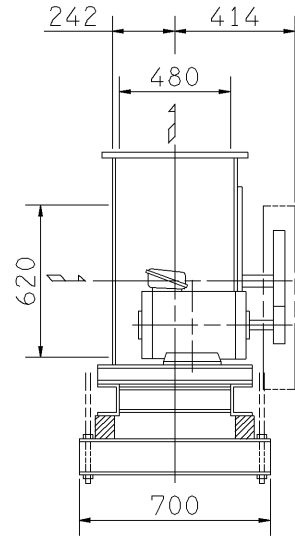

- 注) 1. 本図は、駆動側(プーリ側)より見た図です。
NOTE DRAWING SHOWS THE DIMENSIONS VIEWED FROM PULLEY SIDE.
2. 機器の取付け、配管等は取扱説明書を参照してください。
FOR INSTALLATION PLEASE REFER INSTRUCTION MANUAL.
3. 天井吊りボルトは付属いたしません。
HANGER BOLTS ARE OUT OF SUPPLY.
4. 本図は、エバラ標準電動機を使用した場合の図です。
MOTORS ARE IN ACCORDANCE WITH EBARA STANDARDS.

出力 OUTPUT kW	回転速度 SPEED min ⁻¹	Vプーリ組合せ V PULLEY		Vベルト V BELT				概略寸法 HEIGHT H	概略質量 MASS kg		
		電動機側 MOTOR SIDE	ファン側 FAN SIDE	呼称(号) SIZE							
				型 TYPE	数 Q'TY	f-A f-B	f-C			f-D	
1.5	375	80	315	3V	1	900	900	950	20	202	
		420	80	280	3V	1	850	850			900
2.2	420	90	315	3V	1	900	900	950	20	212	
		495	95	280	3V	1	900	850			900
		535	90	250	3V	1	850	850			900
3.7	495	95	280	3V	2	850	850	900	20	222	
		535	90	250	3V	2	850	850			900
		575	110	280	3V	2	900	850			900
		610	125	300	3V	2	900	900			950
5.5	575	110	280	3V	2	850	850	900	20	242	
		610	125	300	3V	2	900	900			950
		650	110	250	3V	2	850	850			900
		695	140	300	3V	2	900	900			950
7.5	610	120	280	3V	3	900	850	900	20	259	
		650	140	315	3V	2	900	900			950
		695	150	315	3V	2	900	900			950
		730	140	280	3V	2	900	900			950
		780	160	300	3V	2	900	900			950
11	695	140	250	3V	2	900	850	900	20	289	
		730	140	280	3V	3	900	900			900
		780	160	300	3V	3	900	900			950
		820	140	250	3V	3	850	850			900

付属品 ACCESSORIES		特別付属品 SPECIAL ACCESSORIES		電動機 MOTOR		特殊仕様 SPECIAL SPEC.	
1	軸受(駆動側) UCF209 BG (PULLEY SIDE)	8	防振材(ゴム) ISOLATORS (RUBBER)	1	周波数 Hz	Hz	
2	軸受(反駆動側) UCP206 BG (OPPOSITE SIDE)	9	防振ベース VIBRO ISOLATING BASE	2	電圧 V	V	
3	Vプーリ V PULLEY	10		3	出力 kW	kW	
4	Vベルト V BELT	11		4	形式 TYPE		
5	Vベルトガード V BELT GUARD	12		5	メーカー MAKER		
6	共通ベース COMMON BASE	13		6			
7	相フランジ COMPANION FLANGE	14		7			

御注文主 CUSTOMER				機器番号 ITEM NO.			
御使用先 FINAL USER				機器名称 ITEM NAME			
荏原製番 SER.NO.	機名 MODEL	風量 CAPACITY	静圧 STATIC PRESS.	回転速度 SPEED	出力 OUTPUT	数量 Q'TY	
				min ⁻¹			

図番 DWG.NO. Z4SRM45AC 000

Z4SRM45AC

