

外形寸法図
DIMENSIONS

機名 MODEL 21/2DRM3

周波数 FREQUENCY 60 Hz

天井吊り形
HANGER TYPE

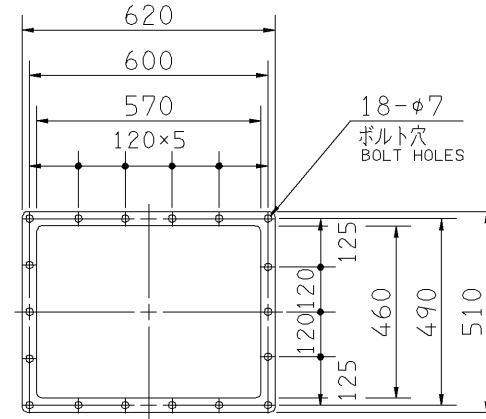
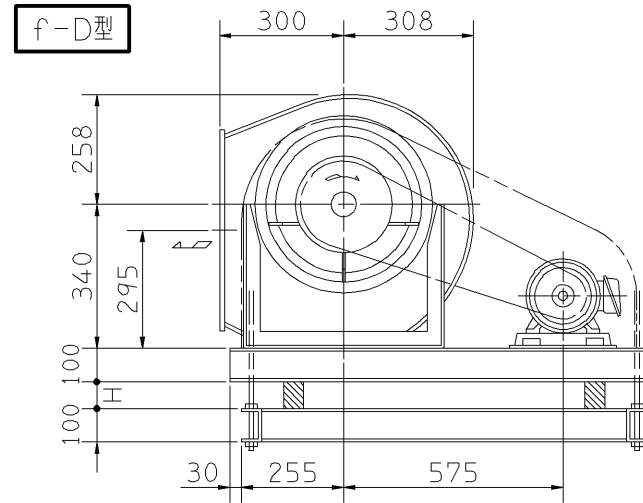
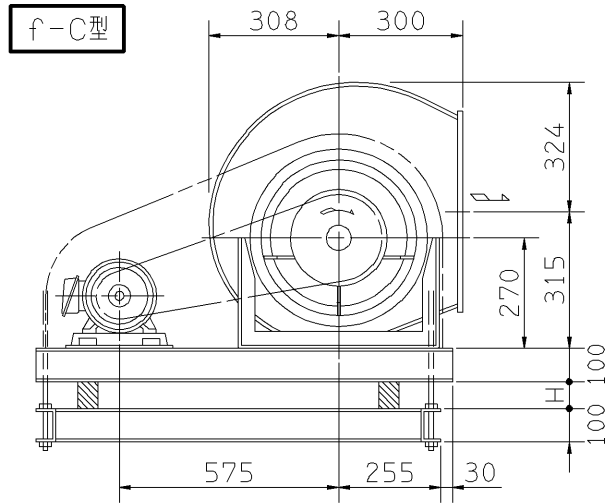
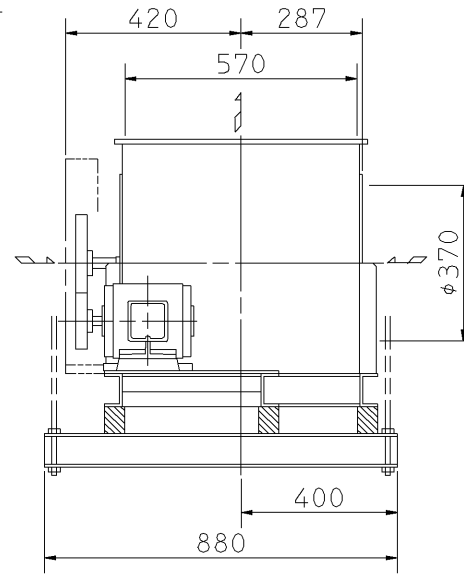
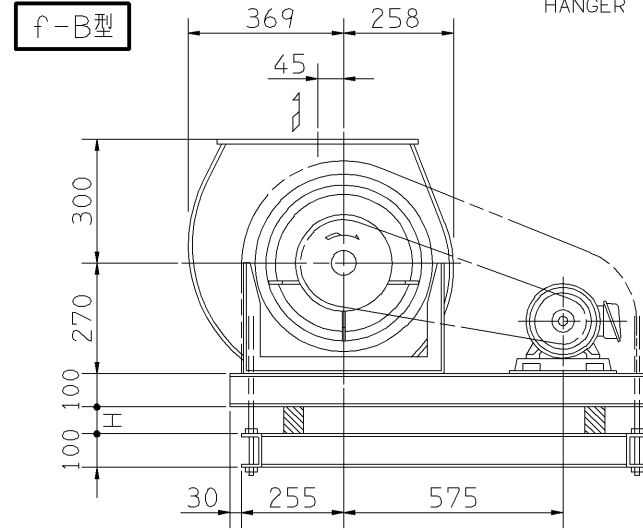
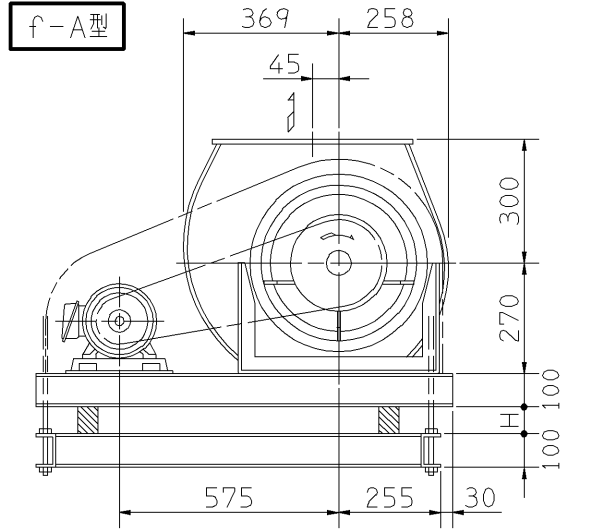

吐出しフランジ
DISCHARGE FLANGE
板厚: t=2,3 THICKNESS

- 注) 1. 本図は、駆動側(プーリ側)より見た図です。
DRAWING SHOWS THE DIMENSIONS VIEWED FROM PULLEY SIDE.
2. Vベルトは全数レッドベルトを使用しています。
ALL MODELS ARE USED MULTIPLE V BELT.
3. 機器の取付け、配管等は取扱説明書を参照してください。
FOR INSTALLATION PLEASE REFER INSTRUCTION MANUAL.

出力 OUTPUT kW	回転速度 SPEED min ⁻¹	Vプーリ組合せ V PULLEY		Vベルト V BELT				概略寸法 HEIGHT H	概略質量 MASS kg	
		電動機側 MOTOR SIDE	ファン側 FAN SIDE	型 TYPE	数 Q'TY	呼称(号) SIZE f-A f-B f-C f-D				
0.75	670	67	190	A	1	63	63	65	22	117
	745	67	170	A	1	62	62	64		
1.5	670	88	250	A	1	68	68	70	22	123
	745	100	250	A	1	69	69	70		
	830	100	224	A	1	67	67	69		
	925	90	180	A	1	64	64	65		
2.2	985	90	170	A	1	63	63	65	36	128
	830	80	180	A	2	63	63	64		
	925	80	160	A	2	60	60	63		
	1070	88	150	A	2	60	60	63		
3.7	925	95	190	A	2	64	64	65	35	140
	985	95	180	A	2	63	63	65		
	1070	100	170	A	2	63	63	63		
	1130	100	160	A	2	62	62	64		
	1180	98	150	A	2	62	62	63		
	1255	98	140	A	2	60	60	62		
5.5	1330	98	132	A	2	60	60	62	35	158
	1130	155	250	B	2	70	70	72		
	1180	140	212	B	2	68	68	69		
	1255	140	200	B	2	67	67	68		
	1330	150	200	B	2	68	68	69		
7.5	1380	140	180	B	2	65	65	67	35	159
	1255	140	200	B	2	67	67	68		
	1330	150	200	B	2	68	68	69		
	1380	140	180	B	2	65	65	67		

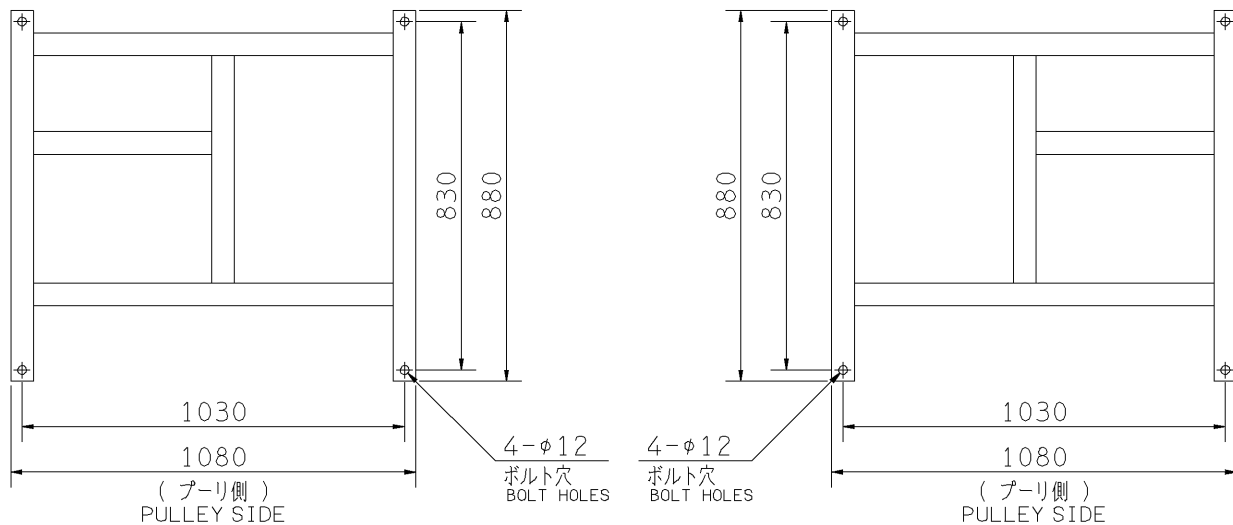

基礎図(上から見る)

基礎図(上から見る)

FOUNDATION PLAN(VIEWED FROM UPSIDE)

FOUNDATION PLAN(VIEWED FROM UPSIDE)

附属品 ACCESSORIES		特別附属品 SPECIAL ACCESSORIES		電動機 MOTOR		特殊仕様 SPECIAL SPEC.	
1	軸受(駆動側) UCPX07 BG (PULLEY SIDE)	8	防振材(ゴム) ISOLATORS (RUBBER)	1	周波数 Hz		Hz
2	軸受(反駆動側) UCP204 BG (OPPOSITE SIDE)	9	防振ベース VIBRO ISOLATING BASE	2	電圧 V		V
3	Vプーリ V PULLEY	10		3	出力 kW		kW
4	Vベルト V BELT	11		4	形式 TYPE		
5	Vベルトガード V BELT GUARD	12		5	メーカー		
6	共通ベース COMMON BASE	13		6			
7	相フランジ COMPANION FLANGE	14		7			

御注文主 CUSTOMER				機器番号 ITEM NO.			
御使用先 FINAL USER				機器名称 ITEM NAME			
原製番 SER.NO.	機名 MODEL	風量 CAPACITY	静圧 STATIC PRESS.	回転速度 SPEED	出力 OUTPUT	数量 Q'TY	
				min ⁻¹			

