

エバラFS型片吸込渦巻ポンプ

EBARA END SUCTION VOLUTE PUMPS

断面図 SECTIONAL VIEW

適用範囲 APPLICATION 40×32FS2E, 2F
50×40FS2E

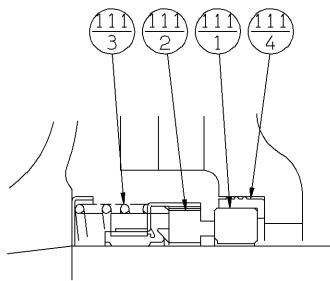
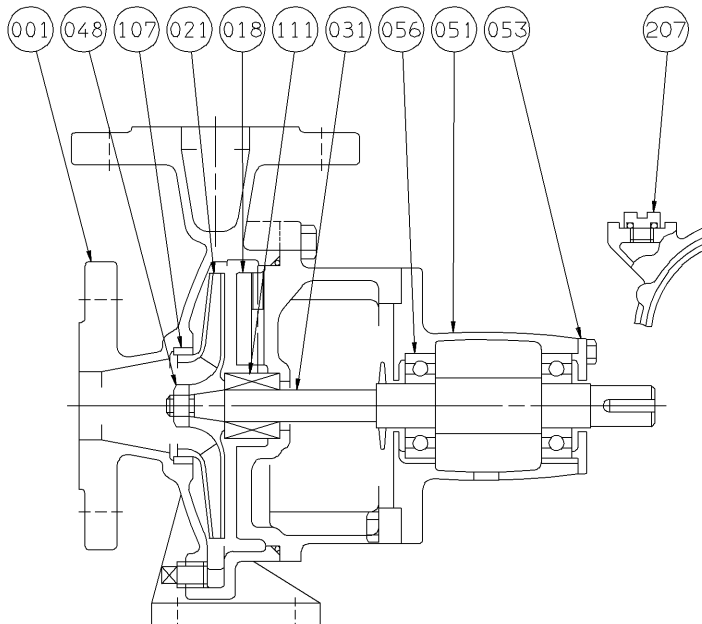

メカニカルシール部詳細
MECHANICAL SEAL DETAIL

番号 PART NO.	部品名 PART NAME	材料 MATERIAL
111-1	固定リング MATING RING	セラミック CERAMIC
111-2	シールリング SEAL RING	カーボン CARBON GRAPHITE
111-3	スプリング SPRING	SUS304 304 STAINLESS
111-4	パッキン PACKING	ゴム/NBR RUBBER/NBR

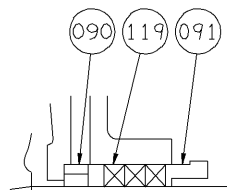

グランドパッキン仕様 (特殊仕様)
GLAND PACKINGS SPECIFICATION (OPTION)

番号 PART NO.	部品名 PART NAME	材料 MATERIAL	個数 NO. FOR 1 UNIT
119	グランドパッキン GLAND PACKING	炭化繊維 CARBONIZED FIBER	3

注記 NOTE ※1: 軸封がグランドパッキン仕様
FOR ONLY GLAND PACKING SPECIFICATION
※2: 全鉄仕様は軸封部グランドパッキン仕様
ALL IRON PARTS FOR ONLY GLAND PACKING SPECIFICATION

207	呼水栓 WATER INLET PLUG	C3771BE	BRASS	FC150	CAST IRON	C3771BE	BRASS		1
111	メカニカルシール MECHANICAL SEAL	セラミック/カーボン	CERAMIC/ CARBON GRAPHITE	※2		セラミック/カーボン	CERAMIC/ CARBON GRAPHITE		1組※2 1SET
107	ライナリング CASING RING	CAC406	BRONZE	FC150	CAST IRON	CAC406	BRONZE		1
091	パッキン押え※1 GLAND	C3771BE	BRASS	FC150	CAST IRON	C3771BE	BRASS		1
090	封水リング※1 LANTERN RING	C3604BD	BRASS	SUM22	CARBON STEEL	C3604BD	BRASS		1
056	玉軸受 BALL BEARING								2
053	軸受カバー BEARING COVER	FC150	CAST IRON	FC150	CAST IRON	FC150	CAST IRON		1
051	軸受ケーシング BEARING HOUSING	FC150	CAST IRON	FC150	CAST IRON	FC150	CAST IRON		1
048	羽根車ナット IMPELLER NUT	C3604BD	BRASS	SUS304 304 STAINLESS	C3604BD	BRASS			1
031	主軸 SHAFT	SUS403	403 STAINLESS	SUS403 403 STAINLESS	SUS304 304 STAINLESS				1
021	羽根車 IMPELLER	CAC406	BRONZE	FC150	CAST IRON	CAC406	BRONZE		1
018	ブラケット BRACKET	FC200	CAST IRON	FC200	CAST IRON	FC200	CAST IRON		1
001	ケーシング CASING	FC200	CAST IRON	FC200	CAST IRON	FC200	CAST IRON		1
番号 PART NO.	部品名 PART NAME	標準仕様 STANDARD		全鉄仕様※2 ALL IRON		主軸材料 304 STAINLESS SHAFT			個数 NO. FOR 1 UNIT
材 料 MATERIAL									

御注文主 CUSTOMER	機器番号 ITEM NO.					
御使用先 FINAL USER	機器名称 ITEM NAME					
荏原製番 SER.NO.	機名 MODEL	吐出量 CAPACITY	全揚程 TOTAL HEAD	同期速度 SPEED	出力 OUTPUT	数量 QTY
				min ⁻¹		